

Homogenizer HL1

- Max. 285 Liters per Hour (200 bar)
- Max. Homogenizing pressure 800 bar (355 l/h)
- Poppet valve and Ball valve execution
- Max. motor power 3 kW
- Weight with motor approx. 300 kg
- Customized execution
- Designed and Made in Germany

Technical changes reserved!



Poppet valves

For low viscosity and slightly abrasive Products

Model	Max. Pressure (bar)	Max. Capacity (Liters per Hour)
HL1.3-200T	200	285
HL1.3-275T	275	230
HL1.3-400T	400	175

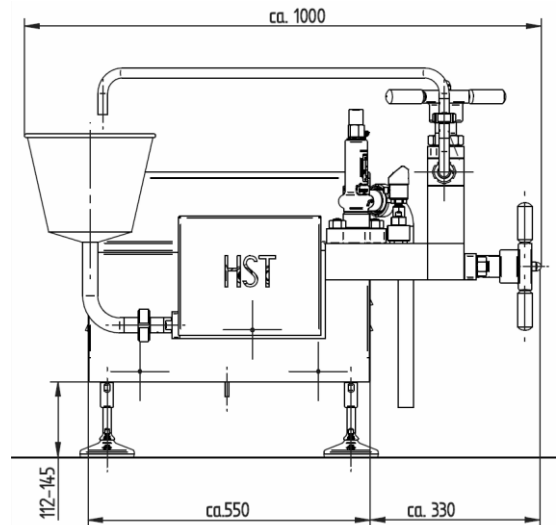

Ball valves

For highly viscous and abrasive Products

Model	Max. Pressure (bar)	Max. Capacity (Liters per Hour)
HL1.3-200K	200	210
HL1.3-275K	275	160
HL1.3-400K	400	125

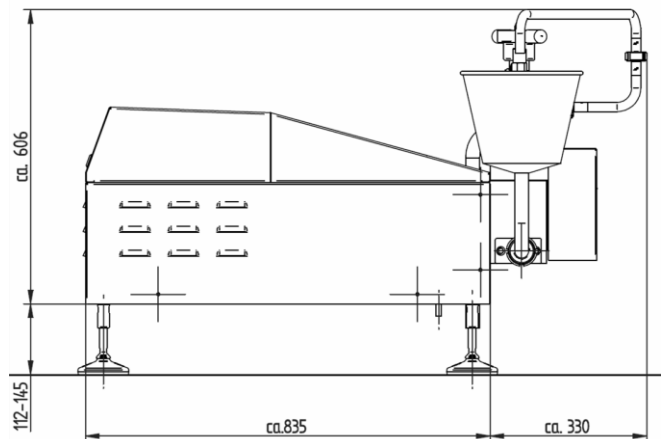

Model	Max. Pressure (bar)	Max. Capacity (Liters per Hour)
HL1.2-700K	700	60
HL1.2-800K	800	55

HST Maschinenbau GmbH • Werkstraße 23 • D-23942 Dassow • Germany
Tel: +49 38826 / 88 78 0 • Email: info@hst-gmbh.com • www.hst-gmbh.com

