

Homogenisator HL2

- Max. 8.000 Liter pro Stunde (70 bar)
- Max. Homogenisierdruck 700 bar (500 l/h)
- Tellerventile und Kugelventile Ausführungen
- Max. Motorleistung 37 kW
- Gewicht mit Motor ca. 1.700 kg
- Optional in aseptischer Ausführung
- Designed and Made in Germany



Technische Änderungen bleiben vorbehalten!

Tellerventile

Für niedrigviskose und nur leicht abrasive Produkte

Modell	Max. Druck (bar)	Max. Durchsatz (Liter pro Stunde)
HL2-70T	70	8.000
HL2-140T	140	5.600
HL2-200T	200	3.500
HL2-250T	250	3.200
HL2-300T	300	2.500
HL2-350T	350	2.000
HL2-550T	550	1.300

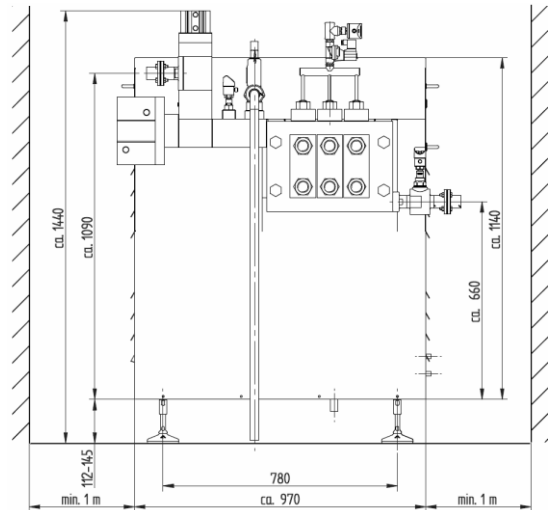

Kugelventile

Für hochviskose und abrasive Produkte

Modell	Max. Druck (bar)	Max. Durchsatz (Liter pro Stunde)
HL2-150K	150	4.000
HL2-200K	200	2.500
HL2-250K	250	2.200
HL2-300K	300	1.800
HL2-350K	350	1.300
HL2-550K	550	800
HL2-700K	700	500

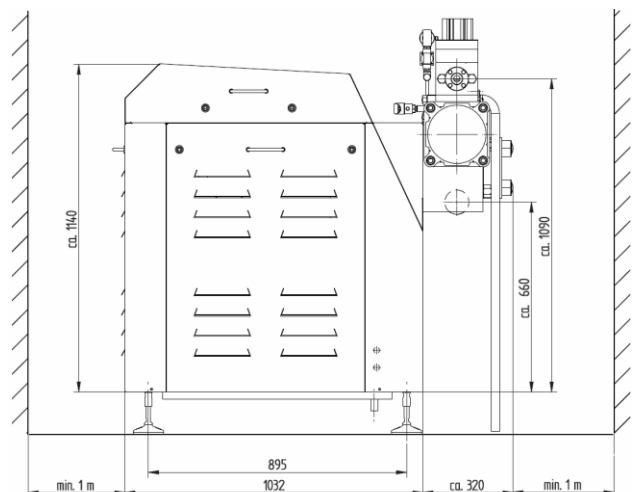

HST Maschinenbau GmbH • Werkstraße 23 • D-23942 Dassow • Germany
Tel: +49 38826 / 88 78 0 • Email: info@hst-gmbh.com • www.hst-gmbh.com

