

# Homogenizer HL2

- Max. 8,000 Liters per Hour (140 bar)
- Max. Homogenizing pressure 700 bar (500 l/h)
- Poppet valve and Ball valve execution
- Max. motor power 37 kW
- Weight with motor approx. 1,700 kg
- Customized execution
- Optional in aseptic execution
- Designed and Made in Germany



*Technical changes reserved!*

## Poppet valves

For low viscosity and slightly abrasive Products

Model	Max. Pressure (bar)	Max. Capacity (Liters per Hour)
HL2-70T	70	8,000
HL2-140T	140	5,600
HL2-200T	200	3,500
HL2-250T	250	3,200
HL2-300T	300	2,500
HL2-350T	350	2,000
HL2-550T	550	1,300

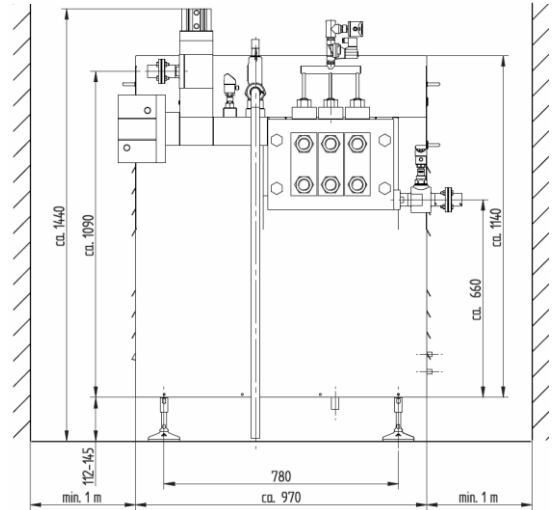

## Ball valves

For highly viscous and abrasive Products

Model	Max. Pressure (bar)	Max. Capacity (Liters per Hour)
HL2-150K	150	4,000
HL2-200K	200	2,500
HL2-250K	250	2,200
HL2-300K	300	1,800
HL2-350K	350	1,300
HL2-550K	550	800
HL2-700K	700	500

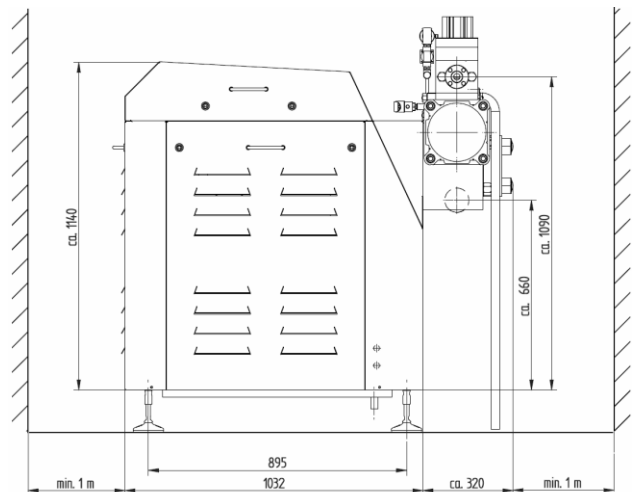

HST Maschinenbau GmbH • Werkstraße 23 • D-23942 Dassow • Germany  
 Tel: +49 38826 / 88 78 0 • Email: info@hst-gmbh.com • www.hst-gmbh.com

