

Homogenizer HL4

- Max. 23,500 Liters per Hour (140 bar)
- Max. Homogenizing pressure 700 bar (4,300 l/h)
- Poppet valve and Ball valve execution
- Max. motor power 132 kW
- Weight with motor approx. 5,400 kg
- Customized execution
- Control Cabinet incl. PLC Control and Touchpanel
- Optional in aseptic execution with sterile water unit
- Designed and Made in Germany

Technical changes reserved!



Poppet valves

For low viscosity and slightly abrasive Products

Model	Max. Pressure (bar)	Max. Capacity (Liters per Hour)
HL4-140T	140	23,500
HL4-180T	180	18,300
HL4-200T	200	16,000
HL4-250T	250	13,500
HL4-300T	300	11,500
HL4-350T	350	9,500
HL4-550T	550	5,000

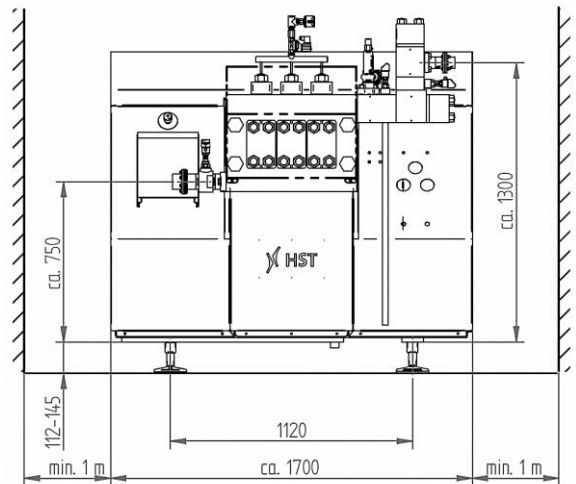

Ball valves

For highly viscous and abrasive Products

Model	Max. Pressure (bar)	Max. Capacity (Liters per Hour)
HL4-150K	150	19,500
HL4-200K	200	15,000
HL4-250K	250	13,000
HL4-300K	300	11,100
HL4-350K	350	9,200
HL4-550K	550	5,400
HL4-700K	700	4,300

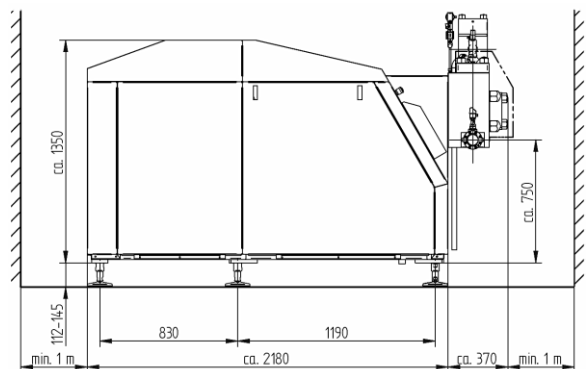

HST Maschinenbau GmbH • Werkstraße 23 • D-23942 Dassow • Germany
 Tel: +49 38826 / 88 78 0 • Email: info@hst-gmbh.com • www.hst-gmbh.com