

# Homogenizer HL5

- Max. 38,500 Liters per Hour (140 bar)
- Max. Homogenizing pressure 700 bar (7,500 l/h)
- Poppet valve and Ball valve execution
- Max. motor power 200 kW
- Weight with motor approx. 7,500 kg
- Customized execution
- Control Cabinet incl. PLC Control and Touchpanel
- Optional in aseptic execution with sterile water unit
- Designed and Made in Germany



*Technical changes reserved!*

## Poppet valves

For low viscosity and slightly abrasive Products

Model	Max. Pressure (bar)	Max. Capacity (Liters per Hour)
HL5-140T	140	38,500
HL5-180T	180	30,000
HL5-200T	200	26,000
HL5-250T	250	22,500
HL5-300T	300	19,000
HL5-350T	350	16,000
HL5-550T	550	9,500

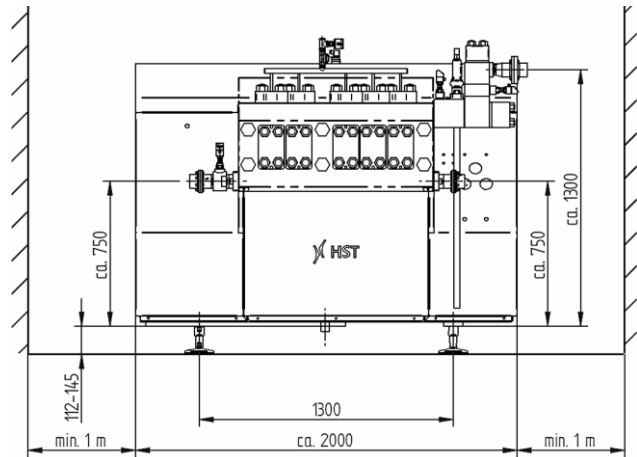

## Ball valves

For highly viscous and abrasive Products

Model	Max. Pressure (bar)	Max. Capacity (Liters per Hour)
HL5-150K	150	32,000
HL5-200K	200	25,000
HL5-250K	250	21,500
HL5-300K	300	18,300
HL5-350K	350	15,300
HL5-550K	550	8,800
HL5-700K	700	7,500

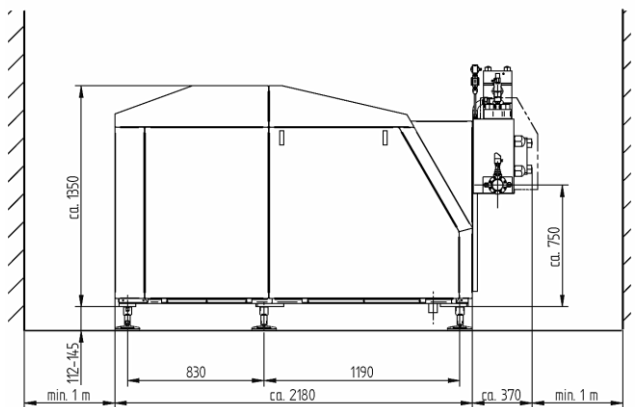

HST Maschinenbau GmbH • Werkstraße 23 • D-23942 Dassow • Germany  
 Tel: +49 38826 / 88 78 0 • Email: info@hst-gmbh.com • www.hst-gmbh.com