

Homogenizer HL6

- Max. 46,000 Liters per Hour (140 bar)
- Max. Homogenizing pressure 700 bar (8,500 l/h)
- Poppet valve and Ball valve execution
- Max. motor power 250 kW
- Weight with motor approx. 7,600 kg
- Customized execution
- Control Cabinet incl. PLC Control and Touchpanel
- Optional in aseptic execution with sterile water unit
- Designed and Made in Germany

Technical changes reserved!



Poppet valves

For low viscosity and slightly abrasive Products

Model	Max. Pressure (bar)	Max. Capacity (Liters per Hour)
HL6-140T	140	46,000
HL6-180T	180	36,000
HL6-200T	200	31,000
HL6-250T	250	27,000
HL6-300T	300	23,000
HL6-350T	350	19,300
HL6-550T	550	11,000

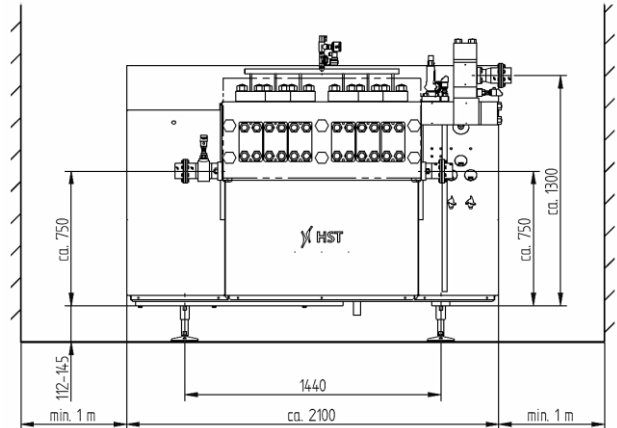

Ball valves

For highly viscous and abrasive Products

Model	Max. Pressure (bar)	Max. Capacity (Liters per Hour)
HL6-150K	150	38,000
HL6-200K	200	30,000
HL6-250K	250	25,500
HL6-300K	300	22,000
HL6-350K	350	18,500
HL6-550K	550	10,500
HL6-700K	700	8,500

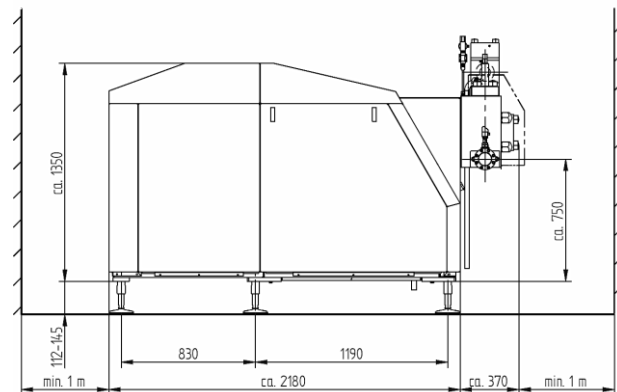

HST Maschinenbau GmbH • Werkstraße 23 • D-23942 Dassow • Germany
 Tel: +49 38826 / 88 78 0 • Email: info@hst-gmbh.com • www.hst-gmbh.com