

Homogenizer HLI55

- Max. 15,500 Liters per Hour (100 bar)
- Max. Homogenizing pressure 700 bar (2,200 l/h)
- Poppet valve and Ball valve execution
- Max. motor power 55 kW
- Weight with motor approx. 2,600 kg
- Customized execution
- Control Cabinet incl. PLC Control
- Optional in aseptic execution with sterile water unit
- Integrated lubrication system
- Lower ecological footprint
- Designed and Made in Germany



Technical changes reserved!

Poppet valves

For low viscosity and slightly abrasive Products

Model	Max. Pressure (bar)	Max. Capacity (Liters per Hour)
HLI55-100T	100	15,500
HLI55-150T	150	10,500
HLI55-200T	200	7,900
HLI55-250T	250	6,200
HLI55-300T	300	5,100
HLI55-350T	350	4,400
HLI55-550T	550	2,700

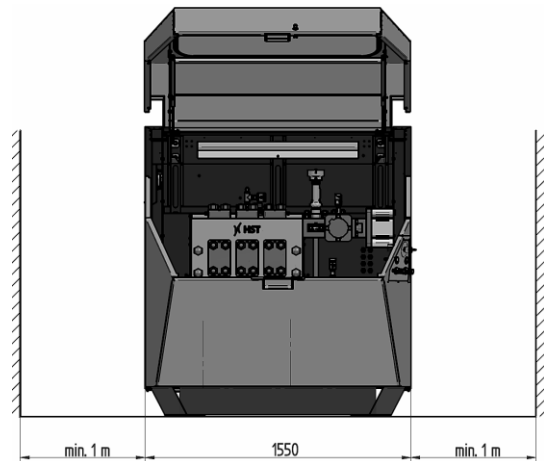

Ball valves

For highly viscous and abrasive Products

Model	Max. Pressure (bar)	Max. Capacity (Liters per Hour)
HLI55-150K	150	10,000
HLI55-200K	200	7,800
HLI55-300K	300	5,100
HLI55-400K	400	3,900
HLI55-550K	550	2,800
HLI55-700K	700	2,200

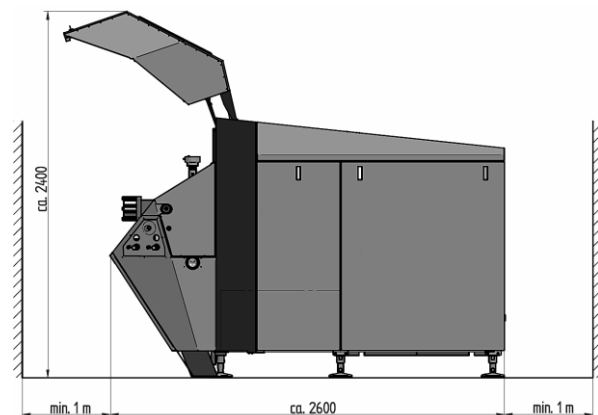

HST Maschinenbau GmbH • Werkstraße 23 • D-23942 Dassow • Germany
 Tel: +49 38826 / 88 78 0 • Email: info@hst-gmbh.com • www.hst-gmbh.com