

Homogenizer HLI75

- Max. 16,000 Liters per Hour (100 bar)
- Max. Homogenizing pressure 700 bar (2,500 l/h)
- Poppet valve and Ball valve execution
- Max. motor power 75 kW
- Weight with motor approx. 2,650 kg
- Customized execution
- Control Cabinet incl. PLC Control
- Optional in aseptic execution with sterile water unit
- Integrated lubrication system
- Lower ecological footprint
- Designed and Made in Germany



Technical changes reserved!

Poppet valves

For low viscosity and slightly abrasive Products

Model	Max. Pressure (bar)	Max. Capacity (Liters per Hour)
HLI75-100T	100	16,000
HLI75-150T	150	14,500
HLI75-200T	200	10,800
HLI75-250T	250	8,500
HLI75-300T	300	7,000
HLI75-350T	350	6,000
HLI75-550T	550	3,800

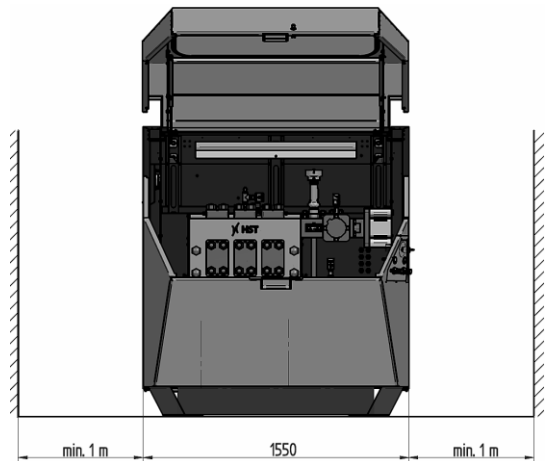

Ball valves

For highly viscous and abrasive Products

Model	Max. Pressure (bar)	Max. Capacity (Liters per Hour)
HLI75-150K	150	14,000
HLI75-200K	200	10,700
HLI75-300K	300	6,500
HLI75-400K	400	5,300
HLI75-550K	550	3,400
HLI75-700K	700	2,500

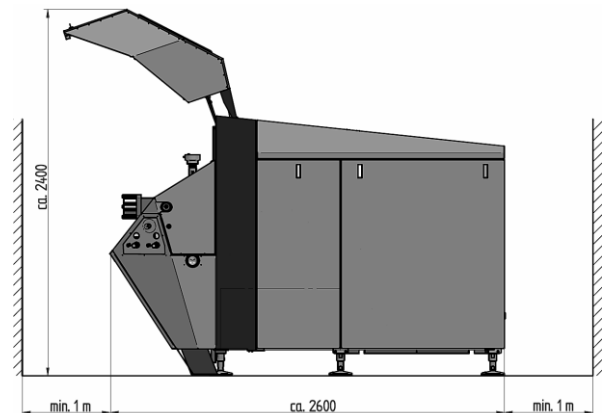

HST Maschinenbau GmbH • Werkstraße 23 • D-23942 Dassow • Germany
 Tel: +49 38826 / 88 78 0 • Email: info@hst-gmbh.com • www.hst-gmbh.com