

Homogenizer HLI8

- Max. 63,000 Liters per Hour (140 bar)
- Max. Homogenizing pressure 600 bar (17,000 l/h)
- Poppet valve and Ball valve execution
- Max. motor power 400 kW
- Weight with motor approx. 11,000 kg
- Customized execution
- Control Cabinet incl. PLC Control and Touchpanel
- Optional in aseptic execution with sterile water unit
- Integrated lubrication system



Technical changes reserved!

Poppet valves

For low viscosity and slightly abrasive Products

Model	Max. Pressure (bar)	Max. Capacity (Liters per Hour)
HLI8-140T	140	63,000
HLI8-180T	180	60,000
HLI8-200T	200	58,000
HLI8-250T	250	47,500
HLI8-300T	300	38,000
HLI8-350T	350	34,000
HLI8-550T	550	20,000

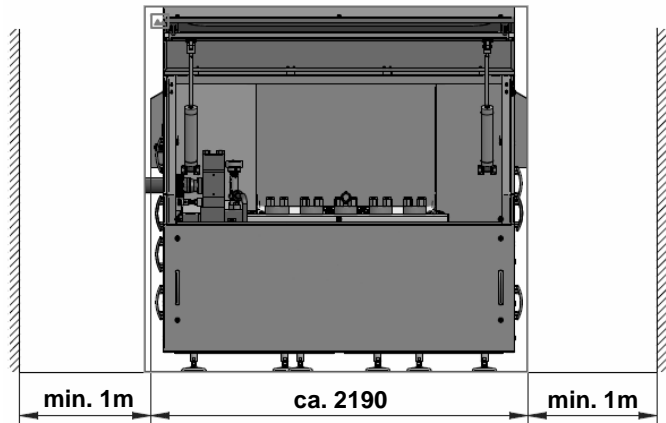

Ball valves

For highly viscous and abrasive Products

Model	Max. Pressure (bar)	Max. Capacity (Liters per Hour)
HLI8-150K	150	61,000
HLI8-200K	200	54,000
HLI8-250K	250	44,000
HLI8-300K	300	35,000
HLI8-350K	350	27,000
HLI8-550K	550	19,000
HLI8-600K	600	17,000

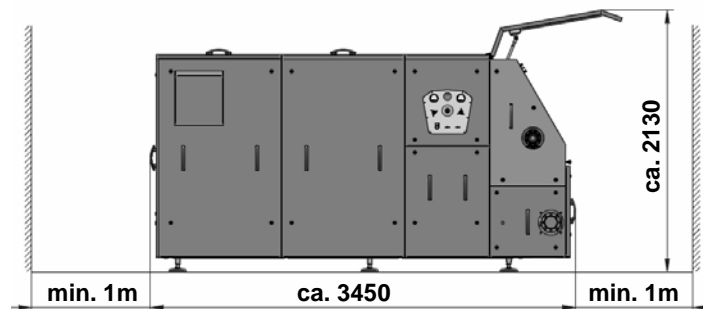

HST Maschinenbau GmbH • Werkstraße 23 • D-23942 Dassow • Germany
 Tel: +49 38826 / 88 78 0 • Email: info@hst-gmbh.com • www.hst-gmbh.com