

# Homogenizer HST - HLE5.5

Standart Capacity 500 LT/H  
 Standard homogenization pressure 200 Bar  
 Absorbed motor power: 5.5 kW  
 Aseptic execution is optional  
 Suitable for processing high viscosity products  
 Unique design in accordance with the conditions of use  
 simple installation, Ergonomic Design, Easy Maintenance

Weight with Motor: Approx 450 kg  
 Technical changes reserved!



Model	Max. Capacity	Max. Pressure
HST-HLE5.5	LT/H (Capacity)	Bar (Working Pressure)
HLE5.5-170	1000	170
HLE5.5-200	500	200
HLE5.5-400	300	400
HLE5.5-700	200	700
HLE5.5-1200	100	1200

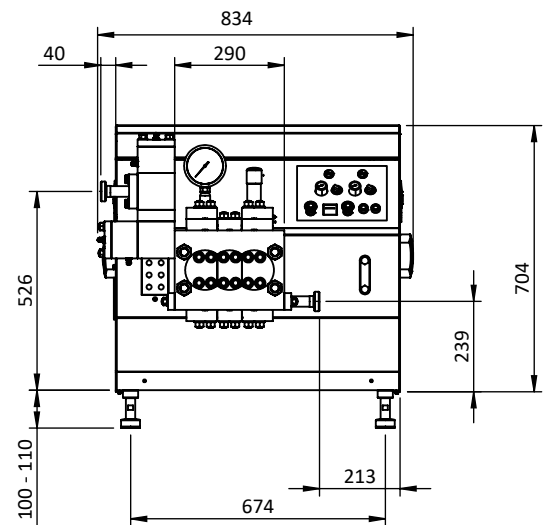

Model	Max. Speed	Max. Diameter
HST-HLE5.5	RPM (Speed)	MM (Diameter)
HLE5.5-170	160	30
HLE5.5-200	118	25
HLE5.5-400	110	20
HLE5.5-700	110	16
HLE5.5-1200	110	12

