

# Homogenizer HST - HLE7.5

Standart Capacity 1.000 LT/H  
 Standard homogenization pressure 200 Bar  
 Absorbed motor power: 7.5 kW  
 Aseptic execution is optional  
 Suitable for processing high viscosity products  
 Unique design in accordance with the conditions of use  
 simple installation, Ergonomic Design, Easy Maintenance

Weight with Motor: Approx 450 kg  
 Technical changes reserved!



Model	Max. Capacity	Max. Pressure
HST-HLE7.5	LT/H (Capacity)	Bar (Working Pressure)
HLE7.5-170	1200	170
HLE7.5-200	1000	200
HLE7.5-400	500	400
HLE7.5-700	300	700
HLE7.5-1000	120	1000

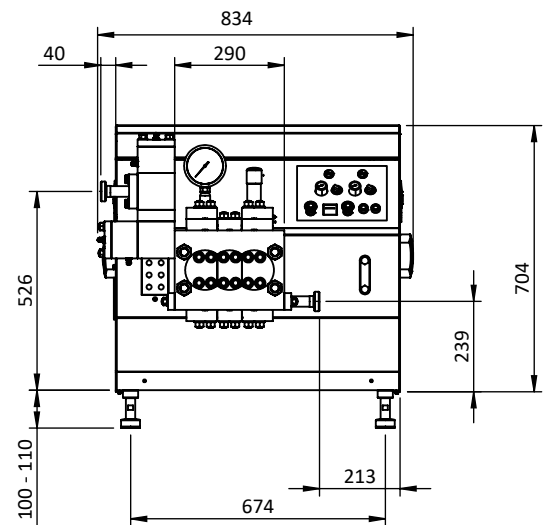

Model	Max. Speed	Max. Diameter
HST-HLE7.5	RPM (Speed)	MM (Diameter)
HLE7.5-170	160	30
HLE7.5-200	118	25
HLE7.5-400	110	20
HLE7.5-700	110	16
HLE7.5-1000	110	12

